

CELL CULTURE MODELS AND PHARMACOLOGICAL PERSPECTIVE FOR THE STUDY OF BREAST CANCER MARKERS

Cristian Layton Tovar¹, Hugo Mendieta Zerón²

¹International Federation of Clinical Chemistry and Laboratory Medicine (IFCC), Professional Scientific Exchange Programme, Sustainable Chemistry Research Center (CIQS) Autonomous University of the State of Mexico (UAEMex), National Autonomous University of México (UNAM)

²Medical Research Center (CICMED), UAEMex; Asociación Científica Latina (ASCILA) and Ciprés Grupo Médico (CGM), Toluca, Mexico

Corresponding Author:

Dr. Hugo Mendieta Zerón
Felipe Villanueva sur 1209
Col. Rancho Dolores 50170
Toluca, México
Tel: +52-722-2194122 Ext. 117
Fax: +52-722-2194122
e-mail: mezh_74@yahoo.com

Key words: breast cancer, cancer markers, cell culture, cytogenetic.

ABSTRACT

Among the most prevalent neoplasias, breast cancer shows an astonishing tendency. Unfortunately this cancer has a high mortality worldwide, requiring sustained management of all actors involved in public health in order to get an early diagnosis and treatment. The methods associated with conventional cytogenetics and molecular cell culture, besides early detection of gene expression patterns associated with cancer susceptibility, have contributed to identify inherited genes and metabolic disorders related to obesity, which are also involved in breast cancer. In any case, a broad study of the above mentioned factors can give a predictive value to support the design of public health models to determine cancer risk in order to decrease the mortality from this disease. (1) Cell cultures offers a wide range of scientific approach for the study of breast cancer, including the analysis of biological function of several compounds in search of increasingly effective treatments with fewer side effects against this malignancy. (2)

INTRODUCTION

Early studies with cell cultures in the nineteenth century were focused on searching new possibilities for clinical diagnosis of diseases of diverse origin, but now this is a scientific tool with a wide range of applications, encompassing both disease conventional diagnosis and molecular cytogenetic techniques such as the ability to improve treatment, prognosis, and patient life expectancy. (3)

The composition and optimization of culture media used in these technical procedures has been in constant changes since 1950. The cell culture process has been used in many scientific fields that cover the synthesis of vaccines, transfection of gene sequences by vectors, gene therapy, models of cell-cell interaction, industrial production and agronomic search for experimental models to study developmental biology and differentiation, signaling, ecology, cell flow and the production of monoclonal antibodies for research and clinical diagnostics.

The study of molecular mechanisms underlying the neoplasia process and the search of its handling or processing in cellular models could contribute to the treatment of a complex series of biochemical reactions characterized by a deregulation in the cell cycle. The genetic alterations may be divided in two groups, a) qualitative (abnormal phenotypic product expression) or b) quantitative (given the reduction or overexpression of a protein involved in the control or cell division that generates the constitutive and structural modification of the parent cell). (4)

The interaction of positive and negative regulators of cellular cycle allows the continuity of organelles replication and production of genetic material for their division or indicates the need to contain the cellular machinery. The positive regulator, also known as oncogenes are genetic sequences that stimulate growth and also control necessary changes for cell division. The negative regulators are tumor suppressor genes, capable to detect DNA damage and repair it through phosphorylation that activate or deactivate a particular function. The study of the cellular cycle regulators as markers of the neoplasia process has an important role in the cancer diagnoses and treatment. (5)

CELL CULTURE CHARACTERISTICS

Conventional cell culture

Pérez et al (6) defines the cell culture technique as an *in vitro* cell growth (Figure 1), replicating the conditions existing *in vivo*. This definition is limited by the conditions of growth and cell proliferation *in vitro*. The structural parameters of the cells, the relations in the tissue formation and the three-dimension structure are different. The factors used for *in vitro* techniques provide cells of all necessary nutritional supplements for DNA synthesis, cell compartment synthesis and clonal expansion to generate two daughter cells from a stem cell.

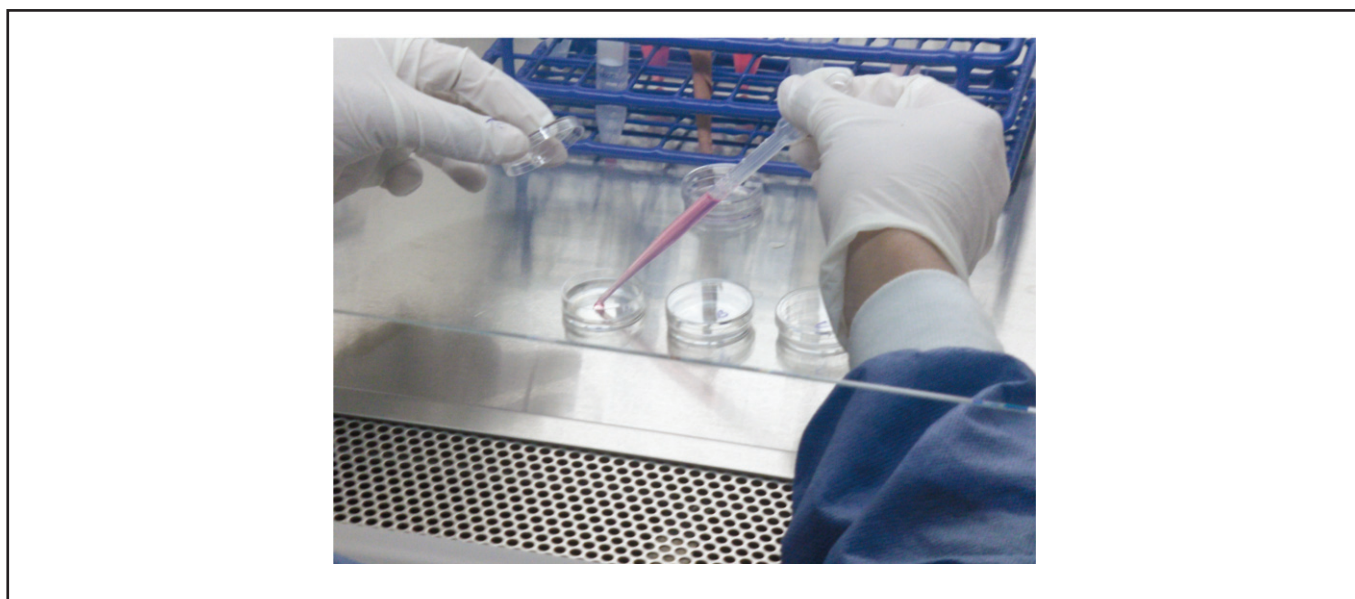

Figure 1
Cells culture model.

Cells in suspension obtained from tissues and biological samples, grow as a monolayer facilitating cell-cell binding through peptide bonds structured in an ordered manner, giving rise to the extracellular matrix and allowing the access to the plate that supports them. However, they proliferate in an undifferentiated manner, in spite of specialized cells that possess certain genetic and metabolic characteristics in relation to its function within the organism, in a cell culture they do not express such properties. Despite the difficulties, it has been achieved the maintenance of living cells outside the body, leading to specialized cell lines, this latter an area of particular interest based on the conservation and expression of its biochemical, genetic and physiological properties. The preservation and expansion of these cell lines requires a complex phenomenon that favors different cellular mechanisms involved in intracellular processes such as organelle assembly, function and differentiation, as well as the nutritional needs for the cell population to get the best kinetics to live under stress conditions.

Cell cultures can be classified according to their origin: peripheral blood, organs, tissues or any other body fluids and secretions. They can also be classified according to the time since it was obtained and whether they have a neoplasia origin.

- **Primary:** Obtained from an organ or tissue. The life time of these cells is limited, so that clonal expansion is not stable, analysis and processing is proportional to its usefulness. Occasionally they can be kept for more generations than expected. (7)
- **Secondary:** Obtained from a primary culture.

- **Primary line:** Refers to a culture established from an organ or tissue that is growing constantly but for a limited time.
- **Continuous cell line:** It is characterized by processes of cell division to be maintained constantly indefinitely. These cell lines are of particular interest in cancer, in fact they may be derived from tumors.

Conventional cell culture is based on treatment for tissue disintegration, either by enzymatic methods, usually with trypsin and collagenase which hydrolyze peptide bonds (constituents of the extracellular matrix) or by mechanical methods; the smallest fraction of the tissue is called explants. This procedure requires high standards of sterility and quality in processing to avoid contamination with microorganisms.

Enzymatic digestion

Since 1950 this option represents the gold standard for obtaining viable primary cell cultures. New procedures standardized the identification of karyotype chromosomal abnormalities associated with a particular genetic pattern and supported the deferential diagnosis of the disease.

Trypsin was one of the first enzymes used in cell culture due to its proteolytic activities, hydrolyzing the disulfide bonds linking the amino acids and disrupting smaller peptides that are digested by other exopeptidases to free amino acids, thus destroying the extracellular matrix. The trypsinization is still used as the standard method. (8)

Cell culture of explants

This technique requires the mechanical fragmentation of the tissue sample into smaller fragments that are adhered to the surface of a culture plate or bracket for the proliferation of peripheral cells of the explant. Finally, four or five explants have contact with the culture medium. The CO₂ exchange and the incubation parameters are vital to the success of the explants vitality, because the cell requires more homologous conditions than when being inside the organism.

Three-dimensional cell culture

This type of culture was developed since 1914 by Harrison (9) followed by Leighton, Curtis, Varde and Bard Elsdale. Until 1977 Bergenholtz developed a millipore membrane method in which fragments of epithelial tissue grow in a controlled manner. This cell culture is useful in evaluating cell morphology, as well as the toxicity of chemicals in industrial products. (9)

Cell culture importance in the solid tumors diagnoses

The importance of cell culture in cytogenetics and the study of chromosomal aberrations wasn't always recognized as today. Before 1970 some cytogeneticists questioned the need to obtain chromosomes which was due to the lack of protocols and knowledge, so its role was not well defined until the advenment of studies that showed that the rate of metaphases obtained in culture allowed the exhaustive analysis of the structural changes associated with the disease. (10)

Cytogenetic techniques were developed with different methods depending on the preference of each laboratory, however it has come a converge in the techniques of tissue sample fragmentation. (10)

Breast cancer characteristics and mammary gland

Breast cancer is the malignant proliferation of cells in normal human mammary gland or in any of their tissues. Osborne (4) defines the mammary gland as a branching ductal-lobular with 15 to 20 lobes drained by the collecting ducts that converge on the nipple in a radial fashion. Each lobe in turn is composed of alveoli that form the functional units of the mammary gland secretion, the terminal duct lobular units (TDLUs). The ducts have a central lumen and are lined with two layers of cells, an inner layer of epithelial cells luminaries and an outer layer of myoepithelial cells. Around this structure is a basal membrane (BM) that separates the epithelium from the stroma. The latter is composed of varying amounts of blood vessels, connective tissue, fat, lymph vessels and nerves (11,12). The malignant transformation model in human solid tumor have three variables; proliferative capacity, evolution and divergence, alterations during evolution and divergence causes many changes in the phenotype (Figure 2).

According to Kopans (6), between 1940 and 1990 the incidence of invasive breast cancer remained largely unchanged, but since that year, it has been increasing in morbidity and mortality in all women around the world. The report of the GLOBOCAN 2008-WHO reported breast cancer has high incidence (13,939 cases (21.2%)) and mortality (5,217 cases (13.3%)) per 100,000 inhabitants of all cancers in women in Mexico. (13)

According to McPherson et.al (14), there is a progressive increase in risk with age in ten-year periods until menopause: The genetic factors associated with inherited cancer are BCRA 1 and 2 genes. Also, genetic polymorphisms associated with the synthesis and metabolism of estrogens is considered to have 4 to 5 times higher risk in women (15).

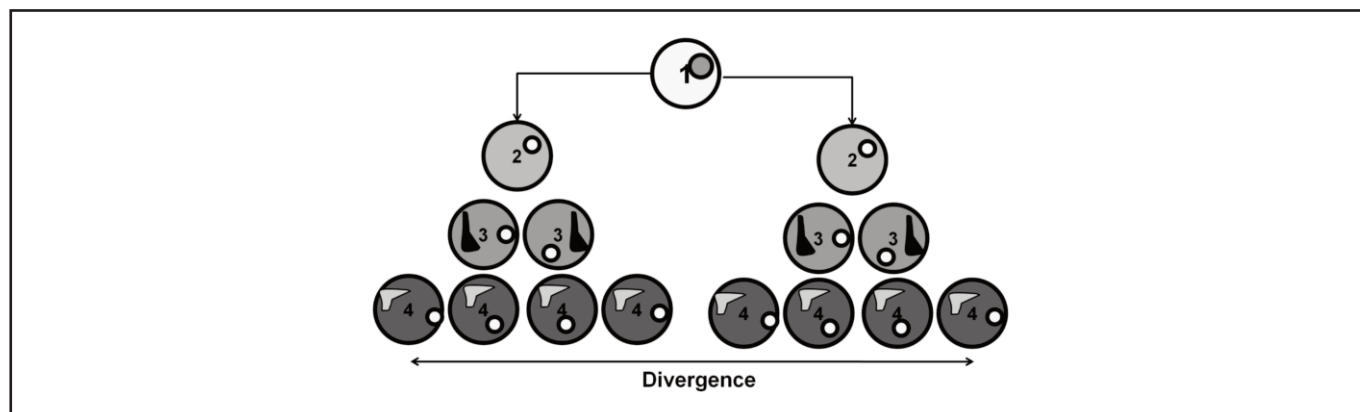

Figure 2
Malignant transformation model:
1) Transformation, 2) Clonal expansion, 3) Additional changes, 4) Gene Amplification.

BREAST CANCER MARKERS

Cyclin E

Recently, Liang et al have reported the use of immortalized normal human mammary epithelial cell line to probe interference RNA (siRNA). This method could effectively inhibit overexpression of both full length and low molecular weight isoforms of cyclin E. In some research reports, cyclin E is aberrantly expressed in many types of cancer including breast cancer. Others have found that high levels of these isoforms of cyclin E are correlated with poor prognosis of breast cancer patients. (1)

Liang et al stabilized this cell line, cultured and transfected with siRNA oligos. The Western blotting, apoptosis and cell cycle analysis, complemented by immunohistochemistry showed that Cyclin E (CycE) overexpression is suppressed in breast cancer cells by siRNA targeting and it induced apoptosis and G1 arrest on the cells. (16)

Cyclin E is a member of the cyclin family, this combines with cyclin- dependents kinases (CDK) (17). There are two types: E1 and E2 located on chromosome 19q12-13. During the G1 phase, CDK2 is activated by cyclin E and via phosphorylation of target proteins, facilitates the progression into the S-phase. The complex Cyclin E-CDK2 has been studied in various carcinomas, especially breast cancer where it has been demonstrated an association between cyclin E levels and the cells capacity to progress through the cell cycle more efficiently. (18)

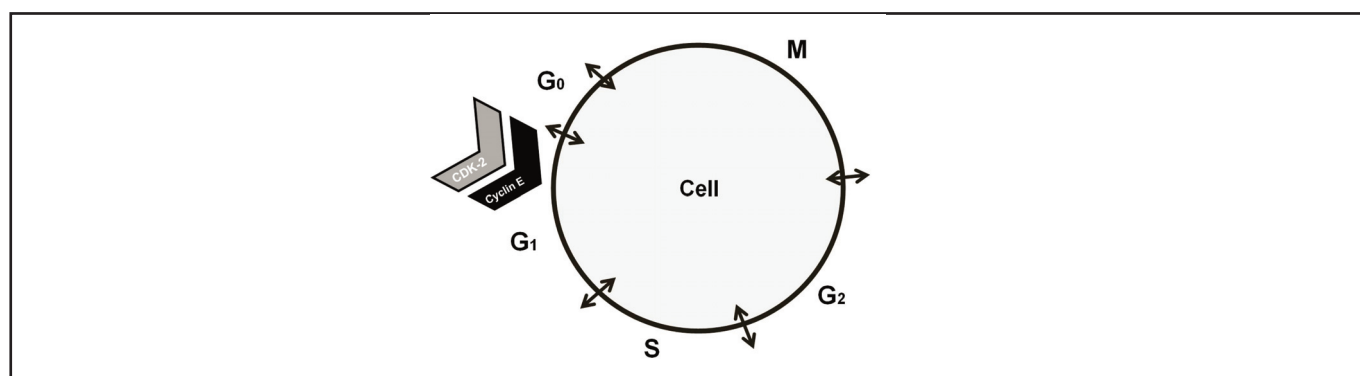

Figure 3
The G₁ to S restriction point is one of the most studied and overexpression of cyclin E, accelerating progression of the cell cycle into the S phase.

Pillay et al evaluated in sixty six cases of breast carcinoma the cyclin E levels and p27 concentrations using immunohistochemistry and demonstrated a statistically significant direct association of cyclin E with distant metastases in all invasive carcinomas. For that population there wasn't a prognostic value of cyclin E, but the direct statistical association with the development of distant metastases reported in previous research may be associated with an aggressive course. (19) Moreover, the cyclin E expression in breast carcinoma is a determinate factor if comparing the results obtained by Scaltritia et al in BT474 modified cellular lines, treated with trastuzumab (resistant and sensible). The pharmacological treatment with trastuzumab in patients HER-2 positives, offers clinical benefits but exist resistance mechanisms mediated by elevated cyclin E expression. Inhibition of cyclin E activity or CDK 2- inhibitor treatment reduces resistance index and induces apoptosis. (20)

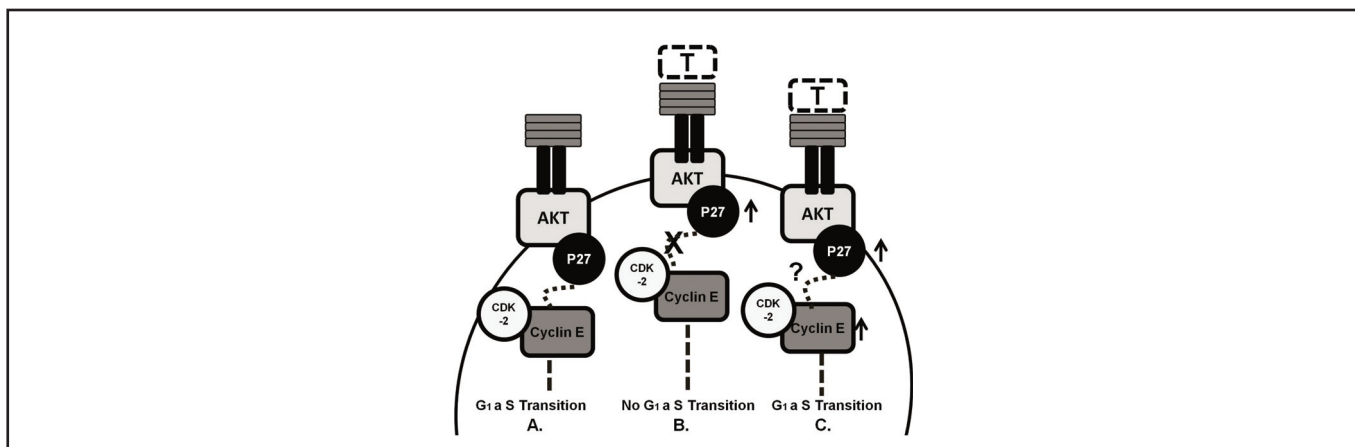

Figure 4
 Progression to G1 a S; HER-2 expressed on the cell surface, increase the AKT and decrease p27 levels stimulating the cyclin E activation mediated by CDK-2. B. Mechanistic of trastuzumab, decrease AKT and increase p27 levels blocking the cyclin E activation mediated by CDK-2. C. Resistance to trastuzumab.

L1 CAM

The L1 CAM gene encodes an axonal glycoprotein belonging to the immunoglobulin supergene family. The cell aggregation is an indispensable process during neural and organ development, immune response and cellular pathway signals, including cellular migration and differentiation. Consisting of several immunoglobulin-like domains and fibronectin-like repeats (type III), is linked via a single transmembrane sequence to a conserved cytoplasmic domain.

In previous studies, it has been reported important concentrations of soluble L1 CAM in breast cancer cell migratory progress: In vitro, L1 CAM correlates to the cell adhesion and active migrations. Abnormal level expression has been found with the breast cancer progression. Yupei et al reported high L1 CAM levels in MDA-MB-231 and MDA-MB-435 cell lines. In this case, this type of cellular line was used to determine L1 CAM using three different polyclonal antibodies, post reverse transcription and construction vector; in this case the protein analysis was effected by western blot and immunohistochemistry. A high concentration of L1 CAM mRNA was reported of this surface protein with molecular weight into the 200-220 kDa range in the cell lines and showed by microscopy. The use of potent antibodies anti-L1 CAM reduced the cellular migration and activation. (21)

Yupei et al demonstrated a positive correlation of L1 expression level with breast cancer cell migratory ability. The L1CAM solubility facilitates cell adhesion and may be a good marker for detection of breast cancer progression and metastatic potential. (21).

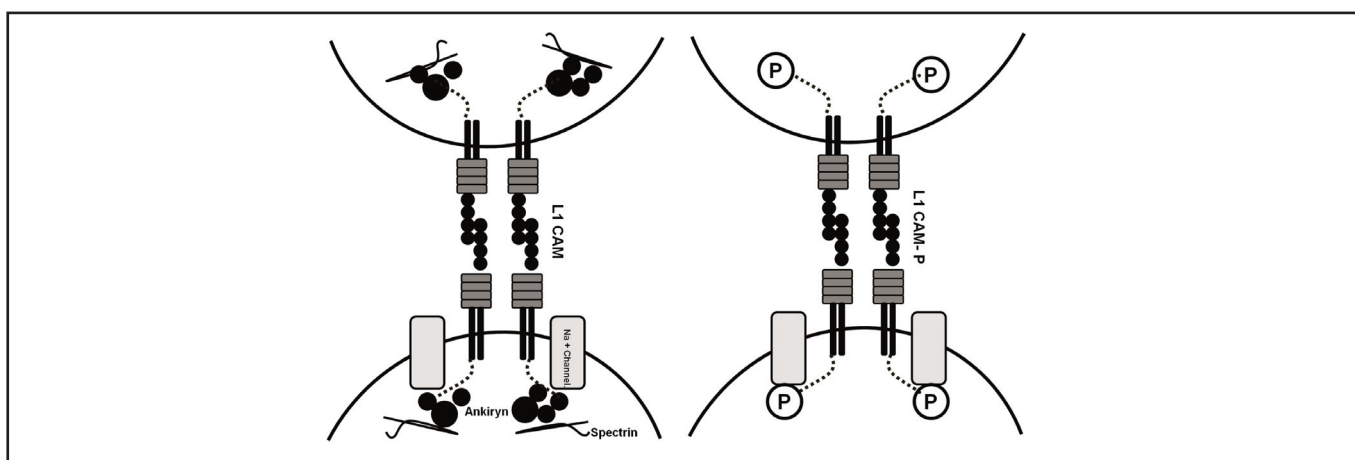

Figure 5
 A schematic model of L1CAM functions involving both unphosphorylated and phosphorylated states. L1 CAM overexpression is correlated in breast cancer cell migratory progress.

EPIDERMAL GROWTH FACTOR RECEPTOR (EGFR)

Epidermal Growth Factor Receptor (EGFR) is a member of the ErbB family of receptors, a subfamily of four closely related tyrosine kinases receptors: EGFR (ErbB-1), HER2/c-neu (ErbB-2), Her 3 (ErbB-3) and Her 4 (ErbB-4). It appears to be mechanistically involved in cell growth and ligand activation is mediated by dimerization enabling EGFR to autophosphorylate. EGFR may be activated by transforming growth factor α (TGF α), but ErbB2 hasn't a direct activating ligand, so it is possible that becomes active upon dimerization with other ligands (22,23). The role of EGFR in some tumor process has been controversial, some authors reported that high levels are not enough for tumor formation. However, others genes has been associated with the EGFR signal, mediated by the receptor tyrosine kinase (Met) and EGFR tyrosine kinase inhibitors (TKIs) that have clinical uses in some types of cancer as lung and pancreatic.

Met has two different activation mechanistic; ligand- independent and ligand- dependent. Overexpression of Met has been associated with breast carcinoma process.

Mueller reported the use of SUM22 cells to study the Met expression and the EGFR regulations by gefitinib. (24) The cell lines used SUM 52, SUM 149, SUM 159, SUM 185, SUM 225, and SUM 229 culture with gefitinib; an EGFR inhibitor. Genetic analysis was doing with a microarray, after the use of an HGF antibody determinates the difference between two cases, complemented with immunoblotting and immunoprecipitation. The principal results determined the clinical use of EGFR inhibitors. Met Kinase overexpression stimulates the cell proliferation, but the manipulation of ligand activation may be decreasing the cell activation levels and the resistance index to gefitinib. (25)

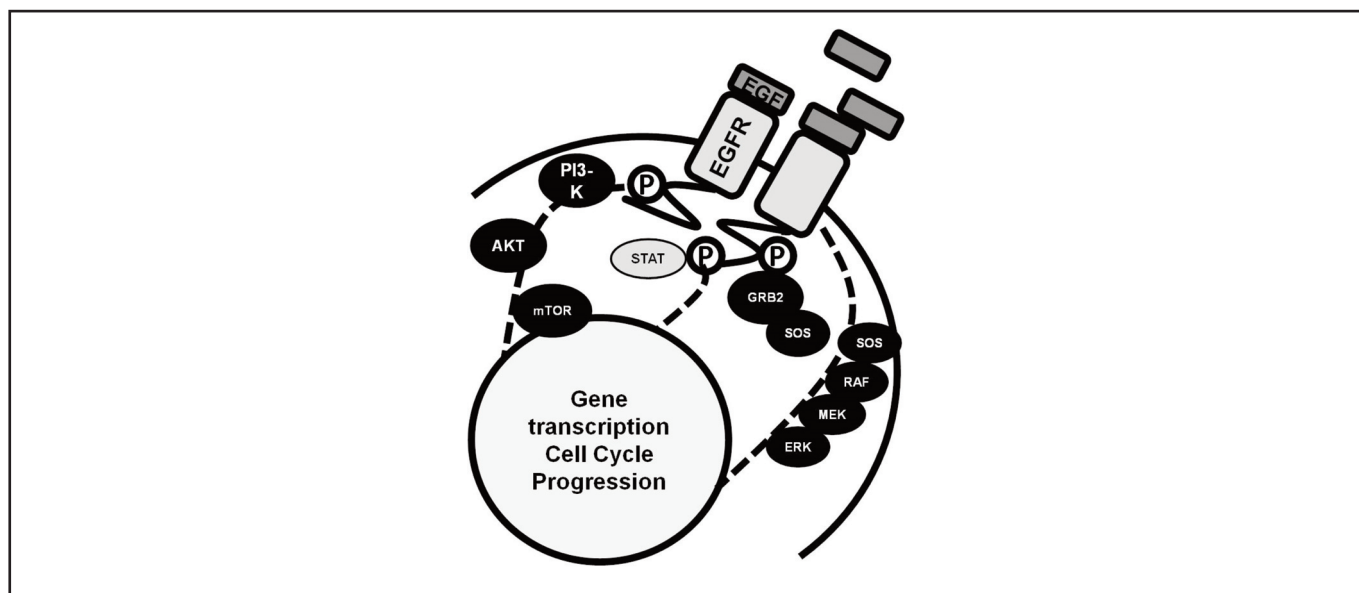

Figure 6

EGFR signal pathway. The EGF- EGFR complex induces cell proliferation, inhibition of apoptosis, angiogenesis, migration, adhesion and invasion.

BRCA1 AND BRCA2 GENES

Puntual mutations, insertions and deletions in BRCA1 and BRCA2 genes predispose women to developing breast and ovarian cancer, BRCA1 genomic rearrangements mainly facilitates malignant cell progression toward cancer. (26) The study of protein drug resistance in breast cancer (BCRP) associated with multidrug resistance has been studied in more than 50 human tumor cell lines tested, six cell lines; A549, NCI-H460, KM -12, HT-29, OVCAR-5, and RPMI8226 demonstrating overexpression of BCRP in the isolation of cDNA in 11 cancer cell lines. Determining polymorphic variant BCRP gene that expresses BCRP C421A in patients with breast cancer has led to current set resistance mechanism to mitoxantrone and irinotecan. (27)

CONCLUSION

The breast cancer markers are an important diagnostic tool to early detection, prognostic and treatment of patients. Cyclin E is aberrantly expressed in many types of cancer including breast cancer and L1CAM soluble concentrations has been reported in breast cancer being both, two possibilities to get news pharmacological perspective. The study of cell cultures is as effective tool to evaluate the breast cancer prognostics in drugs resistance mechanism.

Table 1
Principal characteristics of breast cancer markers

Marker	Type of molecule	Family-Classes	Function	Activation mechanistic	Relation with Cancer process
Cyclin E	Protein	Cyclin family E1, E2.	Facilitates the progression into the S-phase	Phosphorylation by CDK-2	Is aberrantly expressed in many types of cancer including breast cancer. Is a trastuzumab resistance mechanistic
L1 CAM	Protein	Immunoglobulin supergene family	Neural and organ development, immune response and cellular pathway signals, including cellular migration and differentiation	Cellular pathway signals	Abnormal levels expression has been found with the breast cancer progression
Epidermal growth factor receptor (EGFR)	Protein- Receptor	ErbB family of receptors. EGFR (ErbB-1), HER2/c-neu (ErbB-2), Her 3 (ErbB-3) and Her 4 (ErbB-4)		Ligand activation is mediated by dimerization. Autophosphorylate activated by Transforming growth factor α (TGF α).	
Met (Receptor tyrosine kinase)	Protein- Receptor			Ligand- independent and ligand- dependent mediated by dimerization	Overexpression of Met has been associated with breast carcinoma process
Peroxisome proliferator-activated receptor					Abnormal levels expression has been found with the breast cancer progression
Prostaglandin E receptor 4 (Subtype EP4)					Abnormal levels expression has been found with the breast cancer progression

Table 2
Principal characteristics of breast cancer markers

Cell Line	Principal Advantages
MDA-MB-231	Protein expression in different breast cancer stage progress
MDA-MB-435	
BT474 modified	Protein expression in pharmacological treatment
SUM22	Met expression and constitutive phosphorylation, Study EGFR expression

ACKNOWLEDGEMENT

The International Federation of Clinical Chemistry and Laboratory Medicine (IFCC), with the Professional Scientific Exchange Programme financed the academic stay of Christian Layton Tovar at the CIQS.

References

- Hawsawi N, Ghebeh H, Hendrayani S, Tulbah A, Al-Eid M, Al-Tweigeri T, Ajareem D, Alaiya A, Dermime S and Aboussekhra A, Breast carcinoma-associated fibroblasts and their adjacent counterparts display tumor-associated features. King Faisal Specialist Hospital and Research Center, Department of Biological and Medical Research, MBC # 03, PO BOX 3354, Riyadh 11211, KSA.
- Freshney R, Basic Principles of Cell Culture Centre for Oncology and Applied Pharmacology, Cancer Research UK Beatson Laboratories, Garscube Estate, Bearsden, Glasgow G61 1BD, Scotland, UK, i.freshney@ntlworld.com.
- Ryan J, Introduction to Animal Cell Culture Technical Bulletin, Corning Incorporated Life Sciences 900 Chelmsford St. Lowell, MA 01851, On line: http://www.level.com.tw/html/ezcatfiles/vipweb20/img/img/20297/intro_animal_cell_culture.pdf
- Magliocco A, Egan C, Breast Cancer Metastasis: Advances Through the Use of In Vitro Co-Culture Model System
- Gunduz M, Breast Cancer - Focusing Tumor Microenvironment, Stem cells and Metastasis, ISBN 978-953-307-766-6
- Pérez, A., Rodríguez, N., Gil, J. Y Ramirez, G. [CD-ROM]. Tamaño de la muestra. Programa sistemático para el cálculo del tamaño de la muestra y el poder en diseños de investigación. Unidad de epidemiología clínica y bioestadística. Facultad de Medicina. Pontificia

- Universidad Javeriana. [en línea] 2001 [Revisado el 20 de febrero de 2011] On line: <http://www.javeriana.edu.co/Facultades/Ciencias/neurobioquimica/libros/celular/cultivos.ht>
7. Barch J, Knutsen T, Spurbeck J. The AGT cytogenetics Laboratory manual, Association of Genetic Technologists Lippincott-Raven Publishers, 1997 – 666 pages.
 8. Brandan V. Detección del Cáncer de Mama: Estado de la Mamografía en México. *Cancerología* 1 [en línea] 2006 [Revisado el 14 de febrero de 2011] 147-162 On line: <http://www.incan.org.mx/revistaincan/elementos/documentos/Portada/1172289111.pdf>
 9. Rang H, Farmacología. Elsevier España, 2008 - 830 páginas.[en línea] 2008 [Revisado el 18 de febrero de 2011] On line: http://books.google.com/books?id=uo7BNGv51woC&dq=reguladores+positivos+y+negativos+del+ciclo+celular&hl=es&source=gbs_navlinks_s
 10. Instituto Nacional de Investigaciones Nucleares ININ. On line: <http://www.inin.gob.mx/>
 11. Osborne, MP. Breast Anatomy and Development. In: Harris, JR.; Lippman, ME.; Morrow, M.; Osborne, CK., editors. *Diseases of the Breast*. Philadelphia: Lippincott Williams & Wilkins; 2000. p. 1-14.
 12. Weigelt B., Bissell M. Unraveling the microenvironmental influences on the normal mammary gland and breast cancer. Life Sciences Division, Lawrence Berkeley National Laboratory, 1 Cyclotron Road, MS 977-225A, Berkeley, CA 94720, USA
 13. Kopans D, Breast Imaging, 2nd ed., 1999, Lippincott- Raven, Philadelphia, EUA
 14. Cancer Mondial, International Agency for Research on Cancer, IARC, <http://www-dep.iarc.fr>
 15. Mcpherson K, Steel CM AND Dixon JM, Breast cancer. *Epidemiology, risk factors and genetics*. *BMJ* 2000; 321:624-628
 16. Liang Y, Gao H, Lin S-Y, Goss JA, Brunicardi FC, et al. (2010) siRNA-Based Targeting of Cyclin E Overexpression Inhibits Breast Cancer Cell Growth and Suppresses Tumor Development in Breast Cancer Mouse Model. *PLoS ONE* 5(9): e12860. doi:10.1371/journal.pone.0012860.
 17. Grana X, Reddy EP: Cell cycle control in mammalian cells: role of cyclins, cyclin dependent kinases (CDKs), growth suppressor genes and cyclindependent kinase inhibitors (CKIs). *Oncogene* 1995, 11(2):211-219.
 18. Colozza M, Azambuja E, Cardoso F, Sotiriou C, Larsimont D and Piccart MJ: Proliferative markers as prognostic and predictive tools in early breast cancer: where are we now? *Ann Oncol* 2005, 16(11):1723-1739.
 19. Pillay et al.: A Study to investigate the role of p27 and Cyclin E immunorexpression as a prognostic factor in early breast carcinoma. *World Journal of Surgical Oncology* 2011 9:31.
 20. Scaltritia M, Eichhorn P, Cortés J, Prudkin L, Aura C, Jiménez J, Chandarlapaty S, Serra V, Prat A, Ibrahim Y, Guzmán M, Gili M, Rodríguez O, Rodríguez S, Pérez J, Green S, Mai S, Rosen N Hudis C, and Baselga J, Cyclin E amplification/overexpression is a mechanism of trastuzumab resistance in HER2+ breast cancer patients. *Proc National Academy Sciences U S A*. 2011 March 1; 108(9): 3761–3766.
 21. Yupei Li and Deni S Galileo, Soluble L1CAM promotes breast cancer cell adhesion and migration in vitro, but not invasion, *Cancer Cell International* 2010, 10:34 doi:10.1186/1475-2867-10-34
 22. Koenders PG, Beex LV, Geurts-Moespot A, Heuvel JJ, Kienhuis CB, Benraad TJ: Epidermal growth factor receptor-negative tumors are predominantly confined to the subgroup of estradiol receptor-positive human primary breast cancers. *Cancer Res* 1991, 51:4544-4548.
 23. Sainsbury JR, Farndon JR, Needham GK, Malcolm AJ, Harris AL: Epidermal growth- factor receptor status as predictor of early recurrence of and death from breast cancer. *Lancet* 1987, 1:1398-1402.
 24. Singletary SE, Baker FL, Spitzer G, Tucker SL, Tomasovic B, Brock WA, Ajani JA, Kelly AM: Biological effect of epidermal growth factor on the in vitro growth of human tumors. *Cancer Res* 1987, 47:403-406.
 25. Toi M, Osaki A, Yamada H, Toge T: Epidermal growth factor receptor expression as a prognostic indicator in breast cancer. *Eur J Cancer* 1991, 27:977-980.
 26. Mazoyer S. Genomic rearrangements in the BRCA1 and BRCA2 genes. *Hum Mutat*. [en línea] 2001 [Revisado el 20 de febrero de 2011] 25 (5): pp. 415–22. On line: doi10.1002/humu.20169PMID15832305.
 27. Imai Y, Nakane M, Kage K, Tsukajara S, Ishikawa E, Tsuruo T, Miki Y, Sugimoto Y, C421A Polymorphism in the Human Breast Cancer Resistance Protein Gene Is Associated with Low Expression of Q141K Protein and Low-Level Drug Resistance, *Mol Cancer Ther* June 2002 1; 611
 28. Candace A, Ross A. Published in final edited form as: *J Cell Biochem*. [en línea] Diciembre 2009 [Revisado el 28 de febrero de 2011] 108(5): 1031–1038. On line: doi:10.1002/jcb.22350
 29. Mueller K, Yang Z, Haddad R, Ethier S, Boerner J EGFR/Met association regulates EGFR TKI resistance in breast cancer, *Journal of molecular signaling* 2010, 5:8 doi:10.1186/1750-2187-5-8.